

RSA quick guide Polestar 3

Contents

Reset of the infotainment system	2
Attach the tow hook.....	3
Put the car into tow mode	4
Power up a powerless car	7
Charging the 12v battery.....	8

Reset of the infotainment system

Useful if for example a screen turns black or if the infotainment system doesn't work as expected.

Press and hold the Play/Pause button for 30-35 seconds until both screens turn black, then release the button.



Attach the tow hook

The tow hook is stored in the frunk in the same case as the puncture repair kit.

To attach in the front: Remove the cover by pushing its top left corner. The cover loosens and can then be removed.

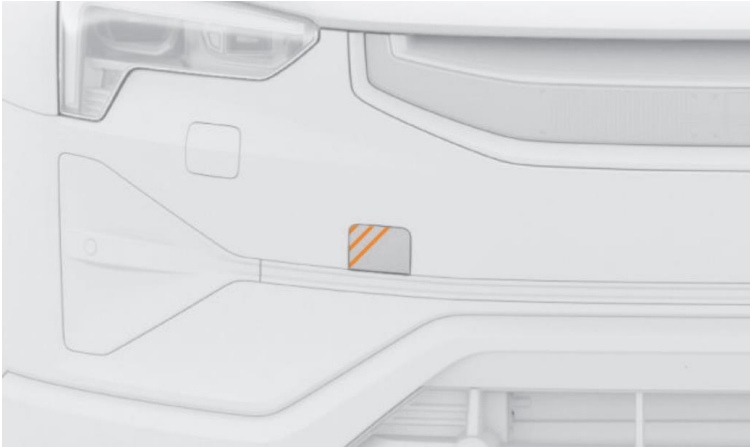

To attach in the rear: Remove the cover by pushing its bottom right corner. The cover loosens and can then be removed



Screw the towing eye all the way into the socket. **IMPORTANT** It is important that the towing eye is firmly screwed into place. Putting something through the towing eye, such as a wheel wrench, can give extra leverage.



Put the car into tow mode

To pull the vehicle onto a flatbed tow truck or to tow it a short distance to a safer place after a stop, use tow mode.

(If tow mode is not possible the car can be pulled onto the flatbed with locked wheels)

Got to Settings

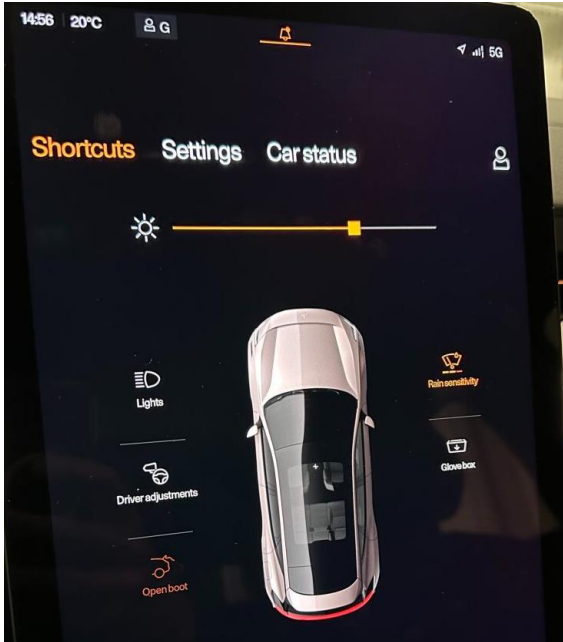

Go to Controls

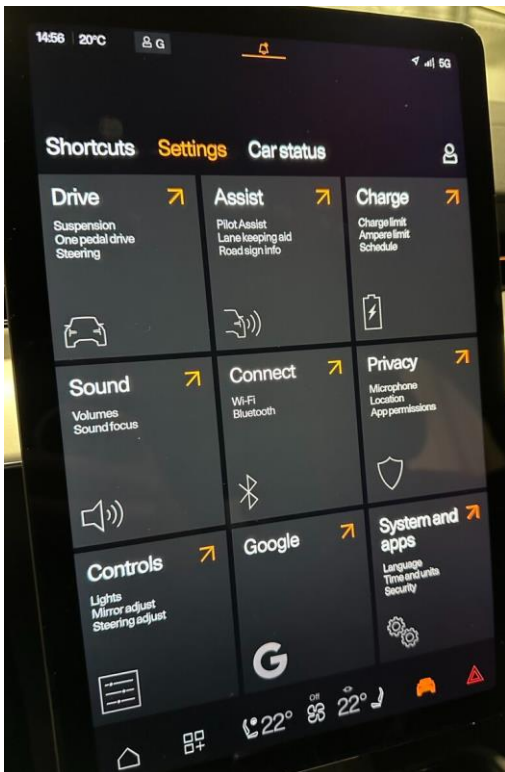

Chose Tow Mode

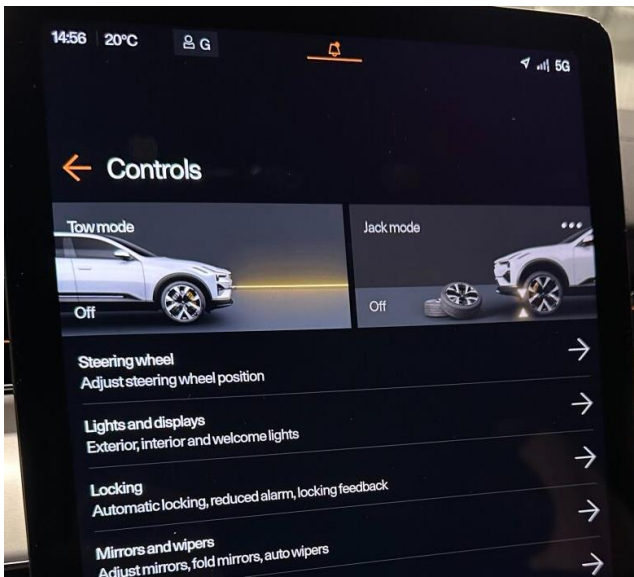

Press Next

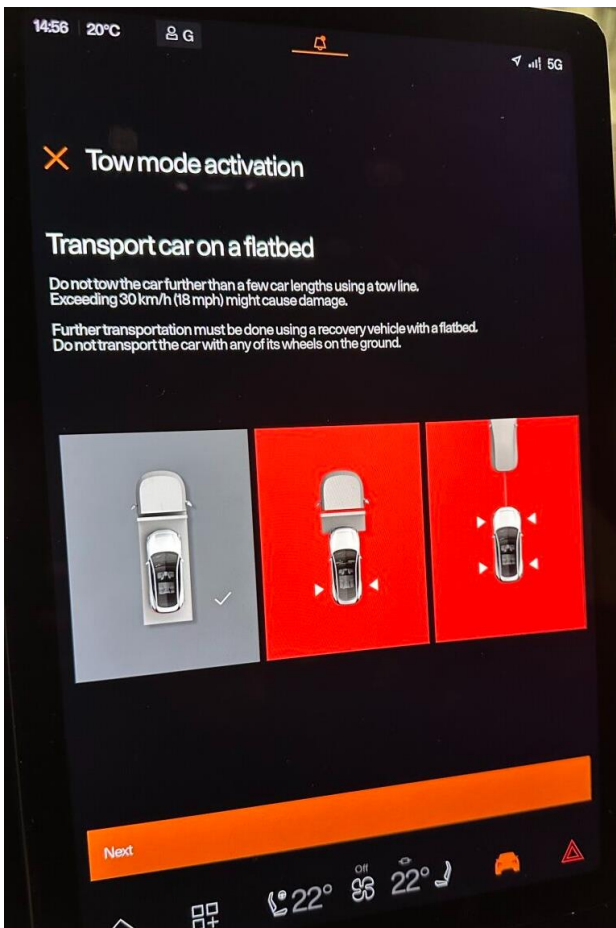

Make sure that the tow hook is in place and that the vehicle is in P. Klick Next.

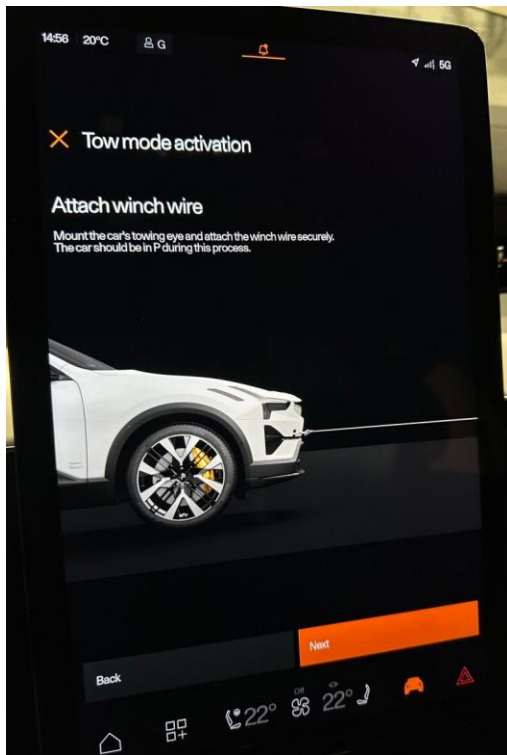

Put the car into N using the gear selector. (The N is not visible in the display at first, apply brake and move the gear selector and it will show)

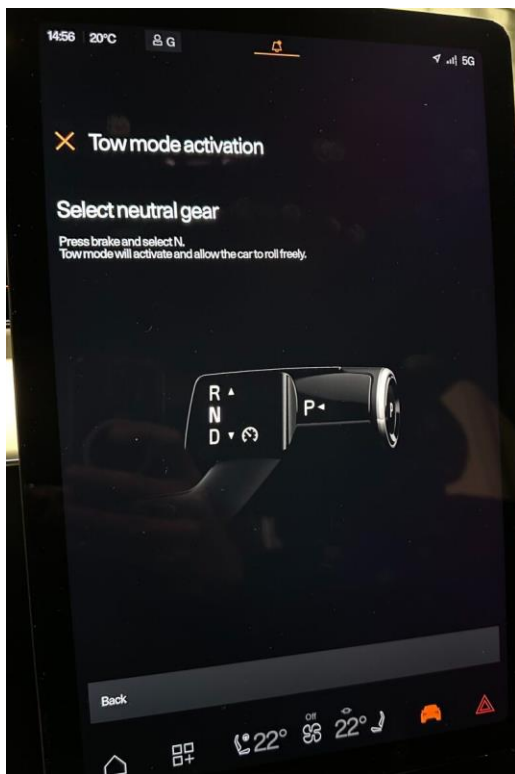

Power up a powerless car

If the car is powerless and locked there is a 12v access point where you can attach power to be able to unlock the doors. Note that the maximum power is 30A and that the access point is only to be used to unlock the car, not for charging the 12v battery. If the maximum power has been exceeded there is a fuse in the access point (2) and an extra fuse in the rubber lid (3). The most forward connection point (1) is positive connection and (4) is minus.

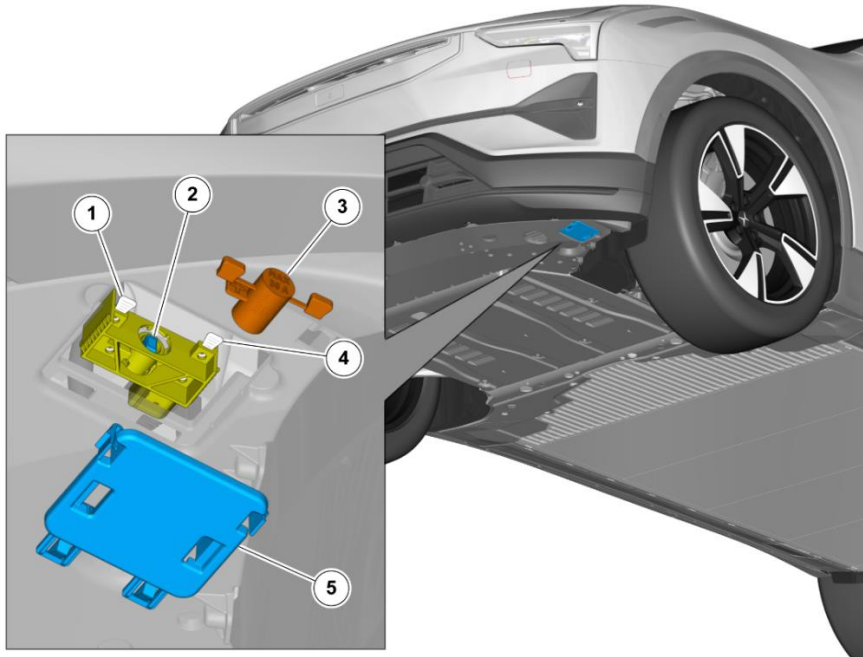

In order to avoid exceeding 30A there is a special tool available from Volvo Car retailer, part no 951-3304. The tool is consisting of two wires with clamps in each end and a 30A wire fuse. The tool is to be used in combination with a separate 12v battery.

If the tool is not available it is possible to use any two wires and a 30A inline fuse instead.



Charging the 12v battery

Remove the four panels surrounding the front storage compartment. They are all fastened with various kinds of clips. 10 clips in the perimeter of the front and side panels are of the kind where you need to push a pin in the middle to release and then remove the clip. The rest comes loose just by pulling the panel.

Remove the storage compartment by removing the four screws.

Now the 12v battery is accessible to charge.

