

# Spare Tire Stowage

## Note:

Depending on the vehicle's trim level, spare tire locations vary from second and third row seating.

### Second Row Seating — If Equipped

For vehicles equipped with second row seating, the spare tire is located in the rear cargo area under the load floor.

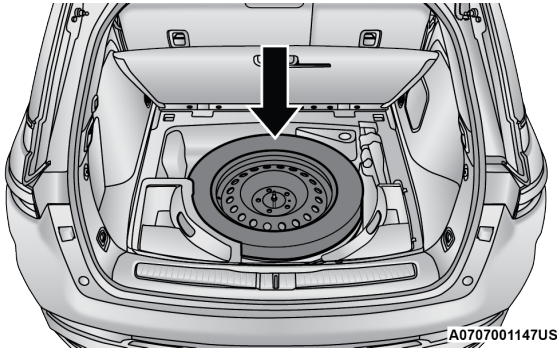

### Spare Tire Location (Second Row Seating)

### Third Row Seating — If Equipped

For vehicles equipped with third row seating, the spare tire is stowed under the rear of the vehicle by means of a cable winch mechanism. To remove or stow the spare, use the jack handle/lug wrench connected to the square socket extension to rotate the "spare tire drive" nut. The nut is located under a plastic cover at the center-rear of the cargo floor area, just inside the liftgate opening.

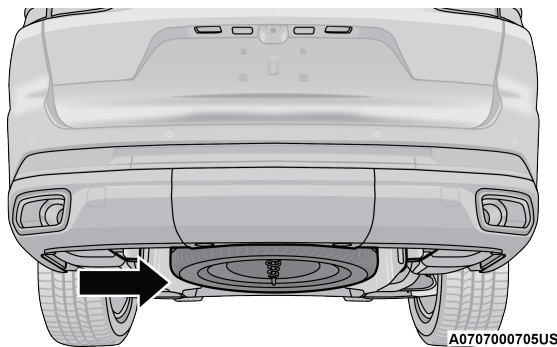

### Spare Tire Location (Third Row Seating)

## CAUTION:

The winch mechanism is designed for use with the jack wrench extension tool only. Use of air wrench or power tool may damage the winch.

# Spare Tire Removal

Remove the spare tire before attempting to jack up the vehicle.

## Note:

Depending on the vehicle's trim level, the procedure for spare tire removal varies for second and third row seating.

### Second Row Seating — If Equipped

1. Lift up on the rear load floor to access the spare tire. Remove the fastener securing the spare tire, and remove the spare tire from the vehicle.

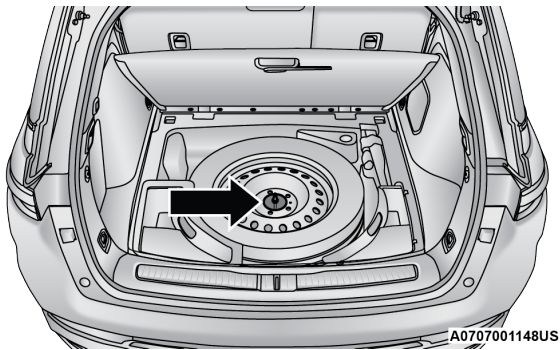

Spare Tire Fastener

2. Remove the spare tire fastener by rotating it counterclockwise.

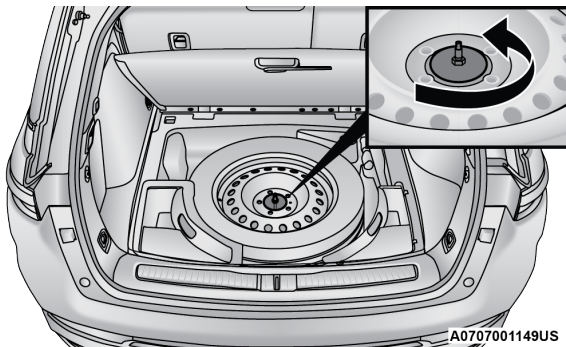

Removing The Spare Tire Fastener

3. After removing the fastener, pull the spare tire up away from the fastener pin and out of the vehicle.

### Third Row Seating — If Equipped

1. Lift up on the rear load floor to access the spare tire winch plug. Locate and remove plug from the storage compartment floor to expose the winch access hole.

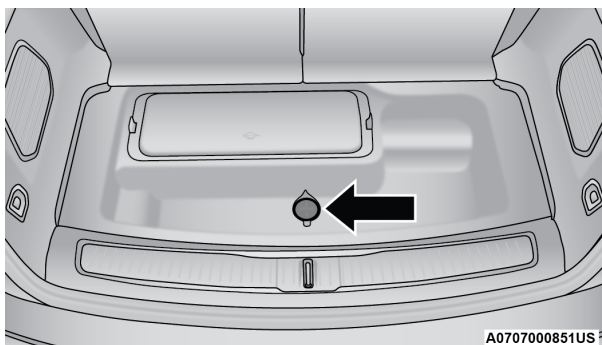

Winch Nut Plug

2. Fit the jack handle extension over the winch drive nut. Use the lug wrench handle and extension to completely lower the spare tire. Keep turning the handle counterclockwise until the winch stops.

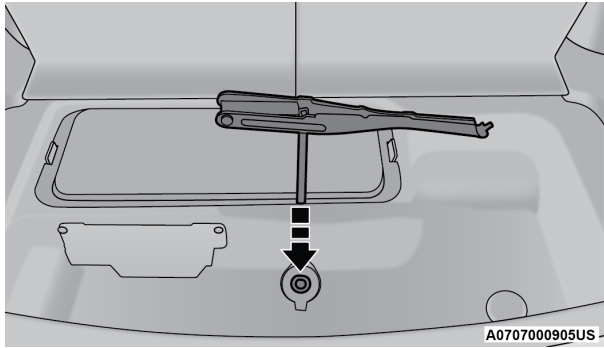

Winch Drive Nut Location

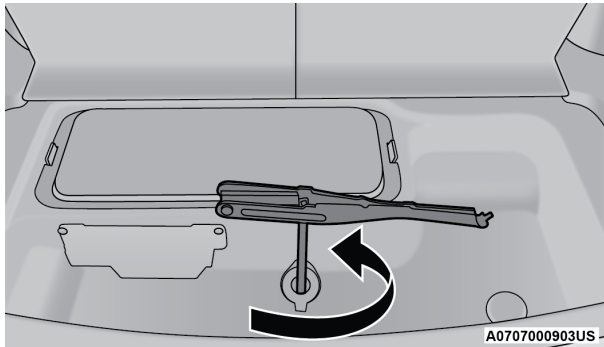

Wrench Rotation

3. Slide the tire out from under the vehicle and rotate it vertically behind the rear fascia/bumper.
4. Pull the metal retainer toward you to release it.

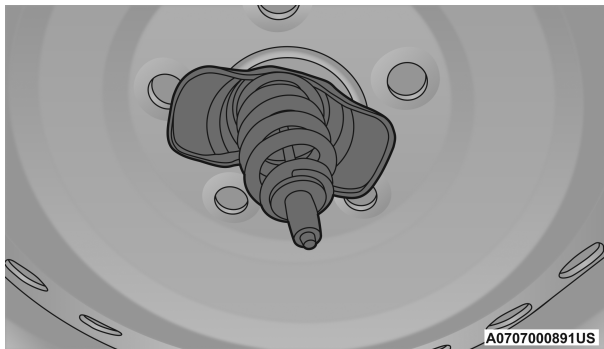

Spare Tire Retainer

5. Slide the retainer up the steel extension tube and winch cable. Rotate the retainer and push it through the hole in the wheel.

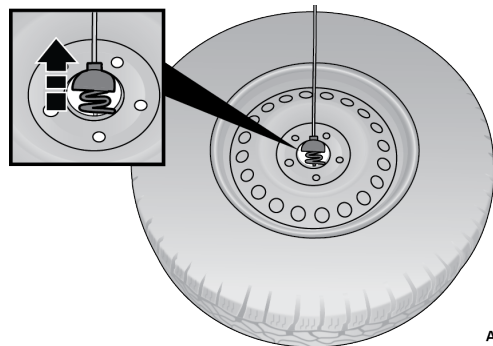

Releasing The Retainer