

Emergency Response Guide



NIRO

ECO electric



Contents

1. Identification / Recognition	3
2. Immobilization / Stabilization / Lifting	7
3. Disable Direct Hazards / Safety Regulations	8
4. Access to the Occupants	13
5. Stored Energy / Liquid / Gases / Solids	16
6. In Case of Fire	19
7. In Case of Submersion	23
8. Towing / Transportation / Storage	24
9. Important Additional Information	27

1. Identification / Recognition

Initial Response: Identify, Immobilize and Disable

The following procedures should be used whenever you are dealing with a Niro EV at an emergency scene. However, all operations should be consistent with your department's standard operating procedures, guidelines, and any applicable laws. When an EV is damaged in a crash, the high voltage safety systems may have been compromised and present a potential high voltage electrical shock hazard. Exercise caution and wear appropriate personal protective equipment (PPE) safety gear, including high voltage safety gloves and boots. Remove all metallic jewelry, including watches and rings.

**WARNING****Identify**

The Niro EV is an electric vehicle. Emergency responders should respond to emergency scenarios involving the Niro EV accordingly, exercising extreme care and caution to avoid contact with the high voltage system within the vehicle.



1. Identification / Recognition

1.1 Identifying a Kia NIRO EV

“Eco electric” Logo on Tailgate

- The Niro EV can be easily identified by the “Eco electric” logo attached on the tailgate and front charge port door on driver’s side.
- The eco electric logo may be missing or hidden after a crash due to damage to the vehicle. Always be sure to utilize additional methods of identification before determining that the vehicle is not a electric car.



Charging Port

- The charging port is located on the front left bumper.

#Note : The doors must be un-locked to open the charge port door.

How to open the charging port



1. Press the unlock door button, depress the brake pedal and apply the Electric Parking Brake (EPB).
2. Turn OFF all switches, move the shift lever to P (Park) and turn off the vehicle.
3. Open the charging door by pressing it.

Unlock charging door in emergency

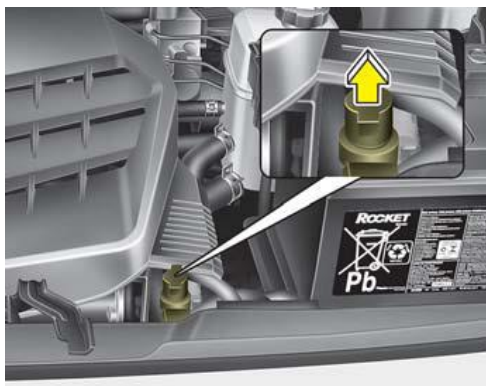

- If the charging port door does not open due to battery discharge, open the hood and pull the emergency cable slightly as shown left.
- The charging port door will then open.

1. Identification / Recognition

1.1 Identifying a Kia NIRO EV

VIN Label

The VIN (Vehicle Identification Number) identifies an electric car with a “G” or “H” displayed in the 8th position, as shown in the below picture.

The VIN can be found:

- 1) VIN Plate can be seen through the windshield from outside.
- 2) On the vehicle certification label attached to the driver’s side (or passenger) center pillar.
- 3) Underneath the front passenger seat (or driver seat).

XXXXXXXX**G**XXXXXXXXXX

← 8th position (G or H)

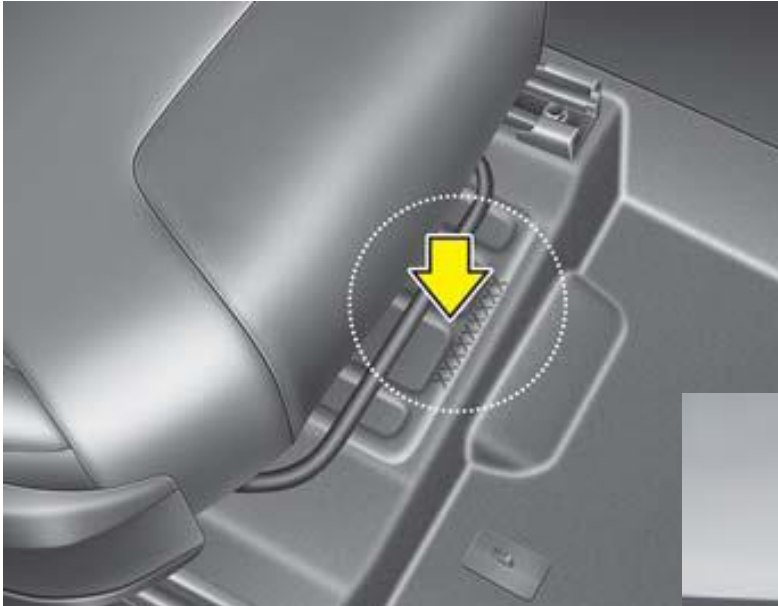

1. Identification / Recognition

1.1 Identifying a Kia NIRO EV

NIRO EV Cluster Instrument Panel

The Niro EV Cluster Instrument Panel displays EV specific features such as high voltage battery SOC (State of Charge) as circled below.



Charge Status Indicator

The battery charge status indicator (3 separate lights), visible from outside on the center of the dashboard, is illuminated when the vehicle is charged with an AC charger. The number of lights illuminated indicates the charge level of the battery.

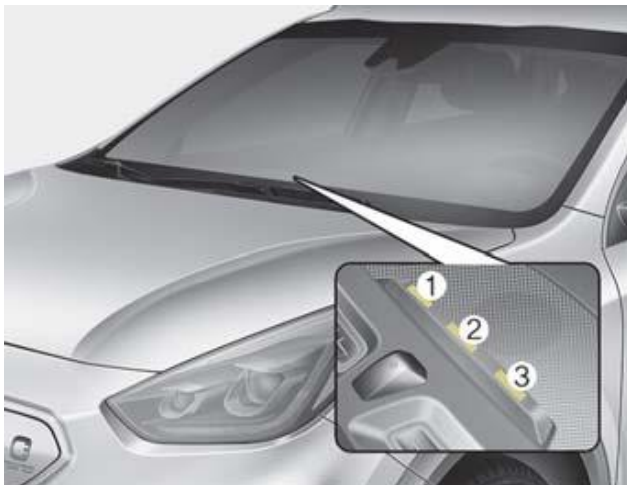

2. Immobilization / Stabilization / Lifting

2.1 Immobilization

The next step is to immobilize the vehicle to prevent any accidental movement that can endanger response personnel or civilians. When the Niro EV is damaged in a crash, the vehicle may appear to be shut off, even when it actually is not, due to a lack of engine sounds.

When the "READY" mode light is illuminated on the Instrument Panel, the vehicle can move silently using the electric motor. Responders should approach the vehicle from the sides and stay away from the front or rear as they are potential paths for vehicle movement. Be sure to immobilize the vehicle in the following manner.



Chock the wheels

Set the Electronic Parking Brake (EPB)

Put the vehicle in P (Park) position by pressing the 'P' button on the rotary shifter

2.2 Vehicle Stabilization

Use standard stabilization (lift) points, as shown beside. Always be sure to connect to a structural component of the vehicle and avoid placing cribbing under high voltage cables, and other areas not normally considered acceptable.

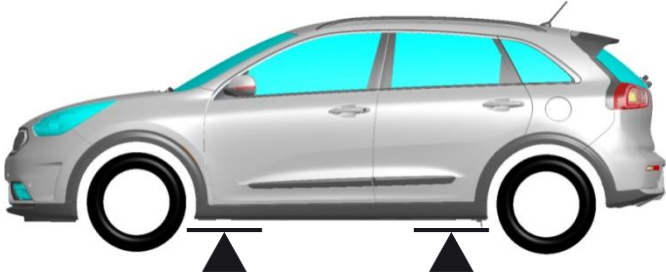

⚠ WARNING

- When installing a block or jack, avoid high voltage cable, battery system.
- If high voltage components or cables are exposed, do not place any support on them.

3. Disable Direct Hazards / Safety Regulations

The final step in the initial response process, conducted after immobilizing the vehicle, is to disable the vehicle, its SRS components and the high voltage electrical system. To prevent current flow through the system, use one of the following procedures to disable the vehicle.

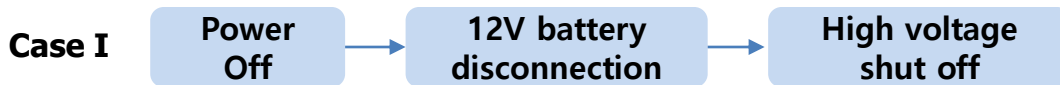

*In case of emergency

3.1 Disabling the System – Smart Key System and “POWER”

START/STOP Button

1. Confirm the status of the READY light on the instrument panel. If the  READY light is illuminated, the vehicle is ON.

a) If the READY light is NOT illuminated, the vehicle is off. Do not push the “POWER” START/STOP button because the vehicle may start (go into READY mode).

b) To turn OFF the system, press the 'P' (Park) button on the rotary shifter dial, and press the POWER button.

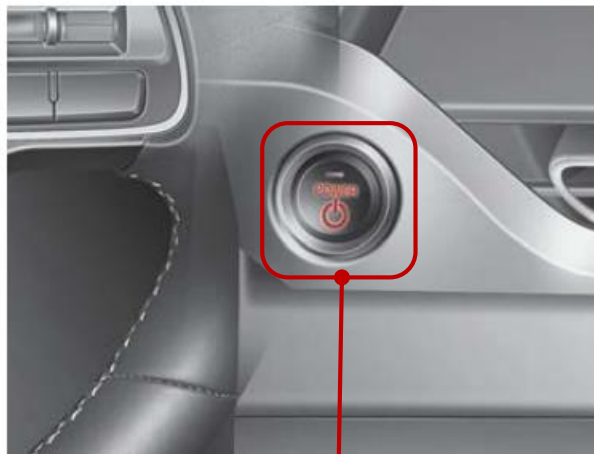

“POWER” START/STOP Button

3. Disable Direct Hazards / Safety Regulations

Without depressing the brake pedal

Pressing POWER button	POWER button LED color	Vehicle condition
One time	Amber	Electrical accessories are operational.
Two times	Reddish orange	The warning lights can be checked before the vehicle is started.
Three times	Off	Off

While depressing the brake pedal

Pressing POWER button	POWER button LED color	Vehicle condition
One time	Off	Ready to drive

2. If necessary, lower the windows, unlock the doors and open the tail gate as required, before disconnecting the 12V battery. Once the 12V battery is disconnected, power controls will not operate. (Refer to below “5. – a” for 12V battery disconnection)

3. Before disconnecting the 12V battery, remove the smart key at least 2 meters away from the vehicle to prevent accidental restart.

4. In case of emergency, cut the service interlock connector cable to isolate the high voltage of the battery.

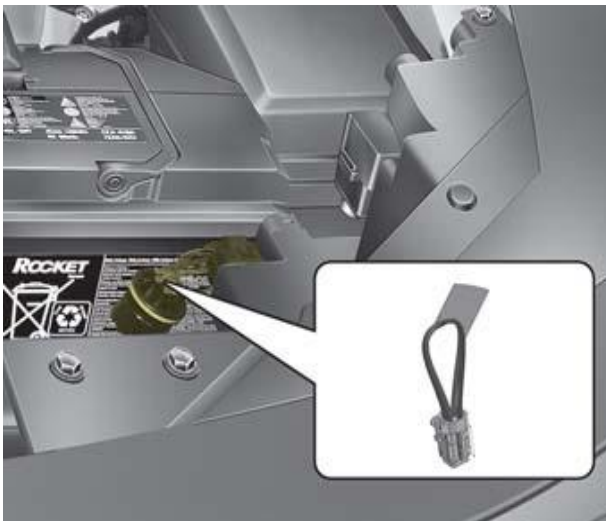

3. Disable Direct Hazards / Safety Regulations

5. Follow the procedure below to remove the safety plug and disable the high voltage battery:

a) Disconnect the 12V auxiliary battery negative (-) terminal.

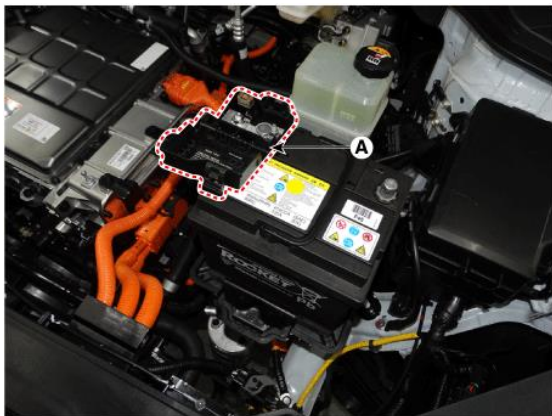

b) Remove the rear seat shown.

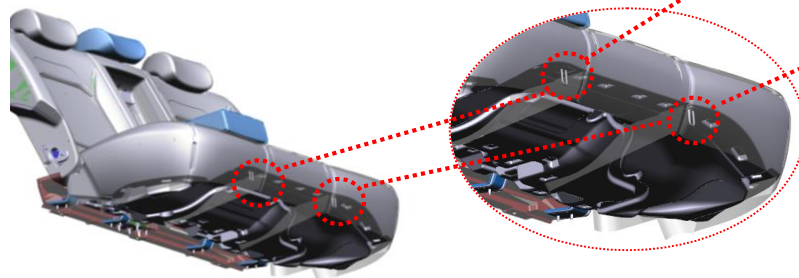
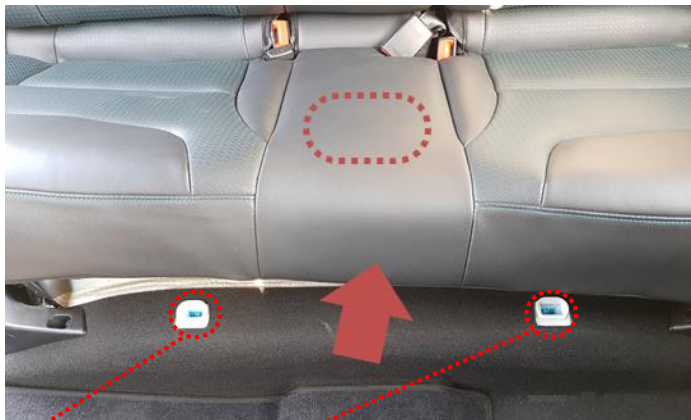

*There are 2 locking hooks.

*Pull the front part of the seat.

c) Remove the service plug cover (A).



d) Remove the service plug (A) by sliding lever and pulling up as shown below.

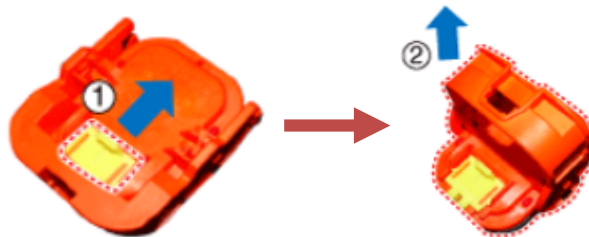
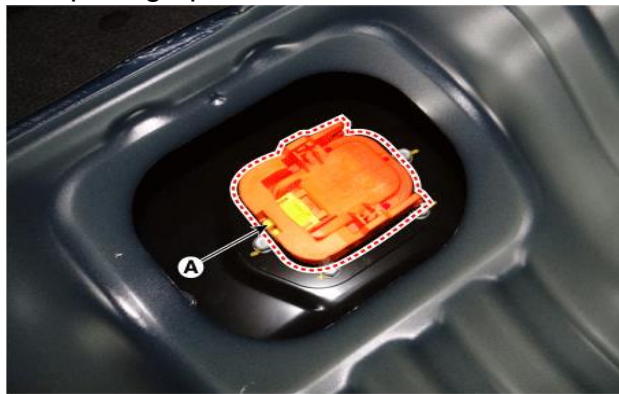

3. Disable Direct Hazards / Safety Regulations

3.2 Disabling the System – IG (Ignition) Fuse Removal

1. Open the hood.
2. Remove the PE(Engine) room fuse box cover.
3. If necessary, lower the windows, unlock the doors and open the tailgate as required, before disconnecting the 12V battery (located in the left side of PE(Engine) room). Once the 12V battery is disconnected, power controls will not operate.

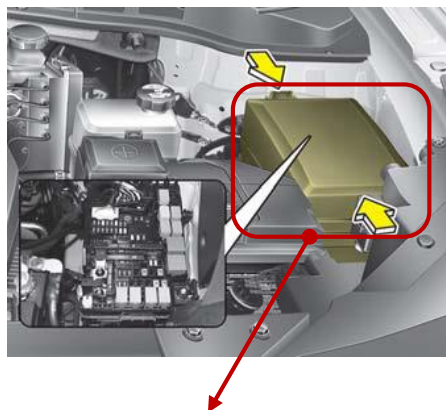

4. In the event the vehicle is unable to be disabled using the “Power” START/STOP Button, using the fuse puller located in the PE(Engine) room fuse box, pull both the IG1, IG2 fuse from the PE(Engine) room fuse box. If the IG fuses cannot be located, pull out all of the fuses and relays in the fuse box.

PE(Engine) room fuse box

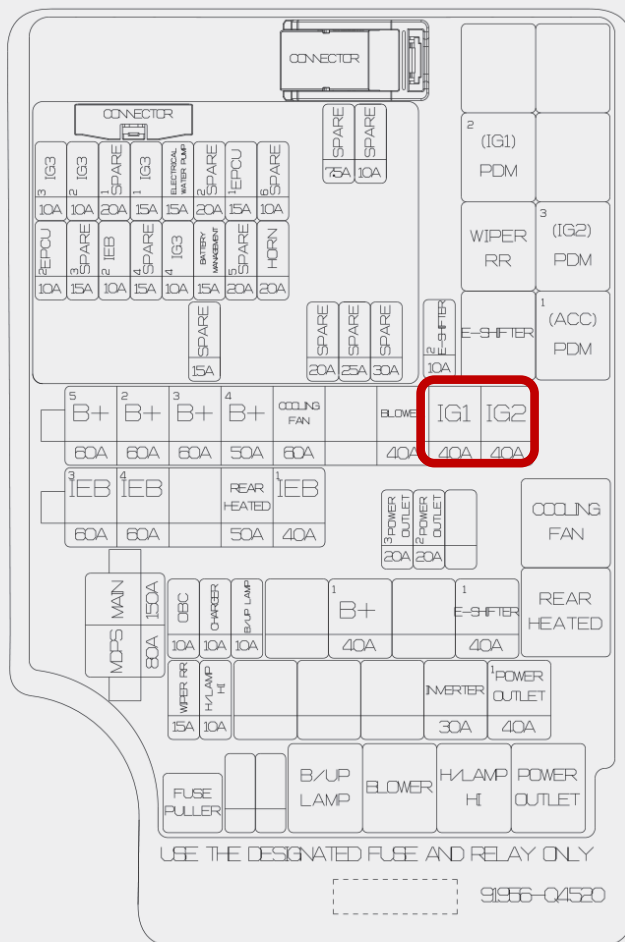

3. Disable Direct Hazards / Safety Regulations

5. Disconnect the 12V battery and disable the high voltage battery by referring to page 9, 10.

If previously mentioned methods of disabling the vehicle's system are unsuccessful, any emergency procedures involving the electric vehicle may cause the accidental deployment of undeployed airbags and electric shock from high-voltage components.

WARNING

Electrocution Risk

- *Before engaging in any emergency response procedures, ensure the vehicle is disabled and wait 5 minutes to allow the capacitor in the high voltage system to discharge to avoid electrocution.*
- *Exposed cables or wires may be visible inside or outside the vehicle. Never touch the metal chassis wires, cables, connectors, or any electric components before disabling the system.*

Failure to follow these instructions will lead to serious bodily injury or death by electrocution.

4. Access to the Occupants

4.1 Extraction Operations

The Niro EV is an electric vehicle. Because of the high voltage components contained therein, first responders should pay special attention when they extract occupants in the car. Before performing any extraction operations, the first responders should "Identify, Immobilize and Disable" the vehicle as discussed in sections on emergency procedures.

4.2 Vehicle Stabilization

Use standard stabilization (lift) points, as shown beside. Always be sure to connect to a structural component of the vehicle and avoid placing cribbing under high voltage cables, and other areas not normally considered acceptable.

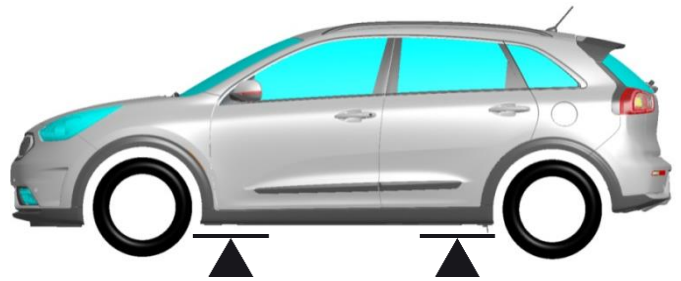

4.3 Extraction Tools and Procedure

When responding to an incident involving a Niro EV, we recommend that the first responders follow their organization's standard operating procedures for dealing with vehicle emergencies. When the first responders cut the vehicle, they should always pay special attention to the airbag system, orange colored high voltage cables and other high voltage components so that the parts are not damaged and to prevent a risk of explosion or electrocution.

4. Access to the Occupants

4.4 Location of Ultra-high Strength Steel

In these images, high strength steel is used in the areas colored in blue and ultra-high strength steel is used in the red colored areas. Depending on the tools used, ultra-high strength steel can be challenging or impossible to cut. If necessary, use a workaround technique.

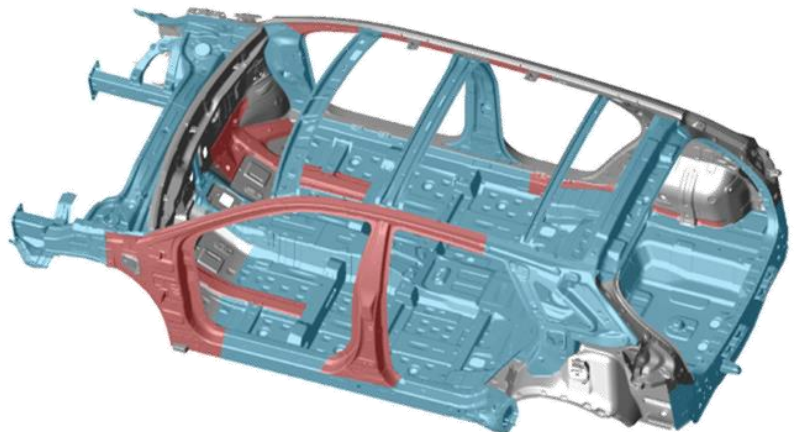
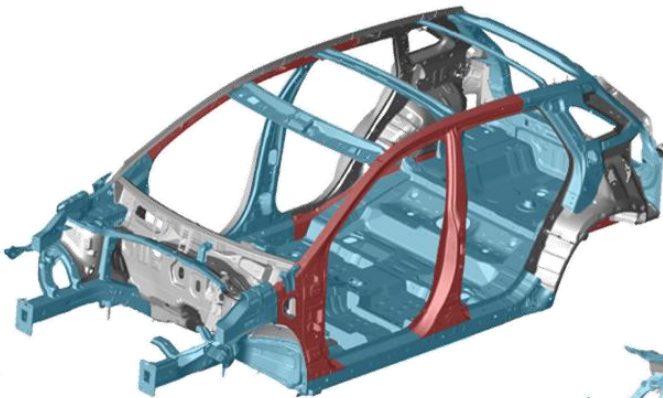
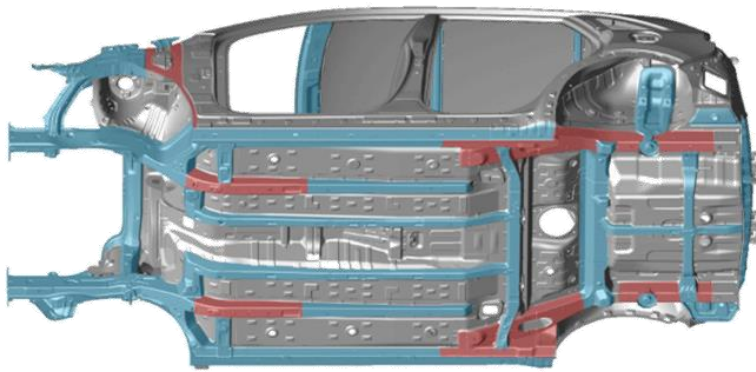

- Mild steel
- High strength steel
- Ultra-high strength steel









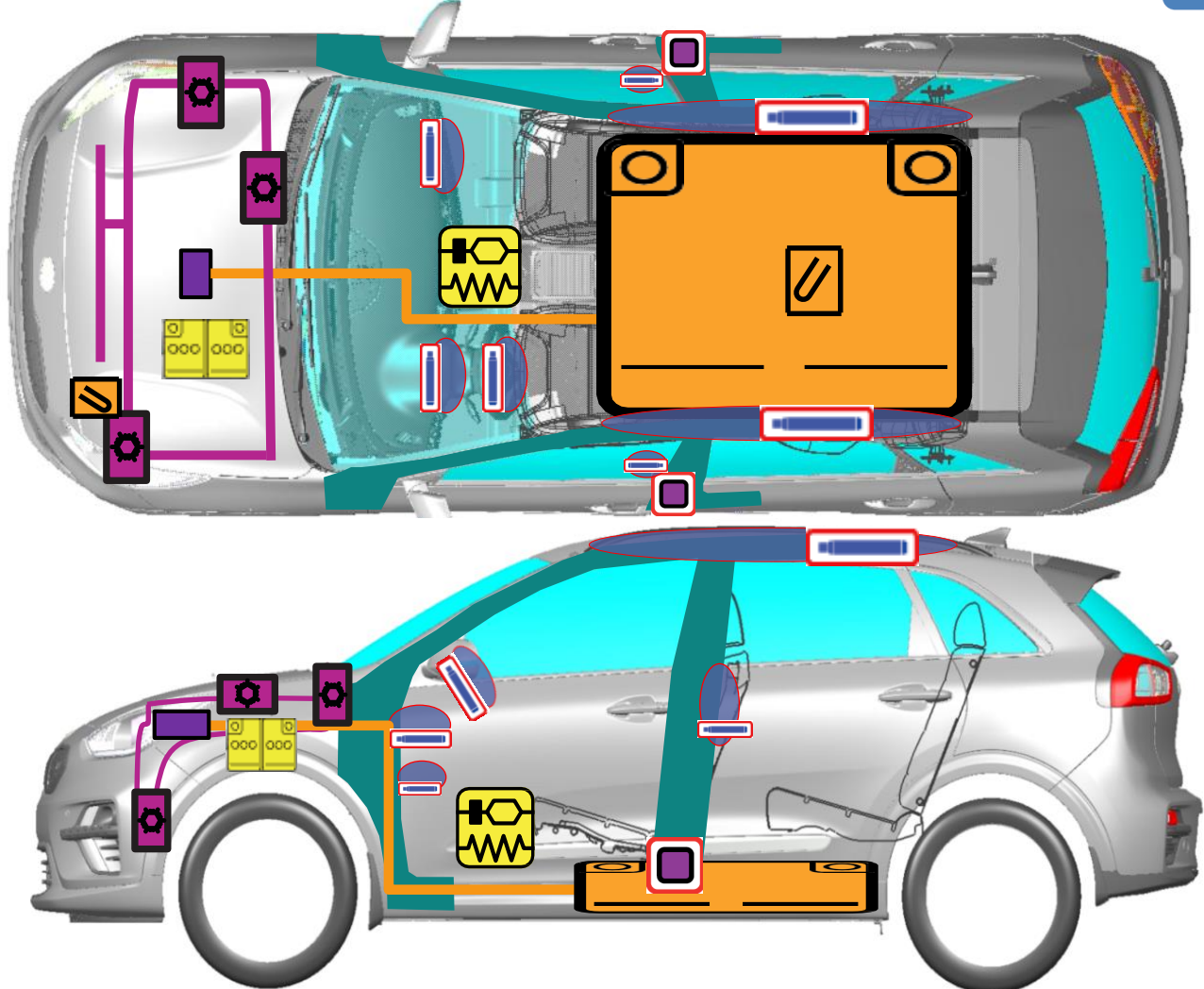



4. Access to the Occupants

4.5 Occupants Rescue Guide

When dealing with an emergency situation, refer to the components as below.

Do not cut the body near the airbag, high voltage cable, fuel system.



 Supplemental Restraint System Control Module (SRSCM)	 Airbag	 Airbag Inflators
 High voltage cable	 12V Battery	 Air-conditioning line
 Service Plug	 OBC (On – Board Charger)	 Ultra-High Strength Steel
 High Voltage Battery	 Air-conditioning component	 Seat belt pretensioner

5. Stored Energy / Liquid / Gases / Solids

5.1 High Voltage System

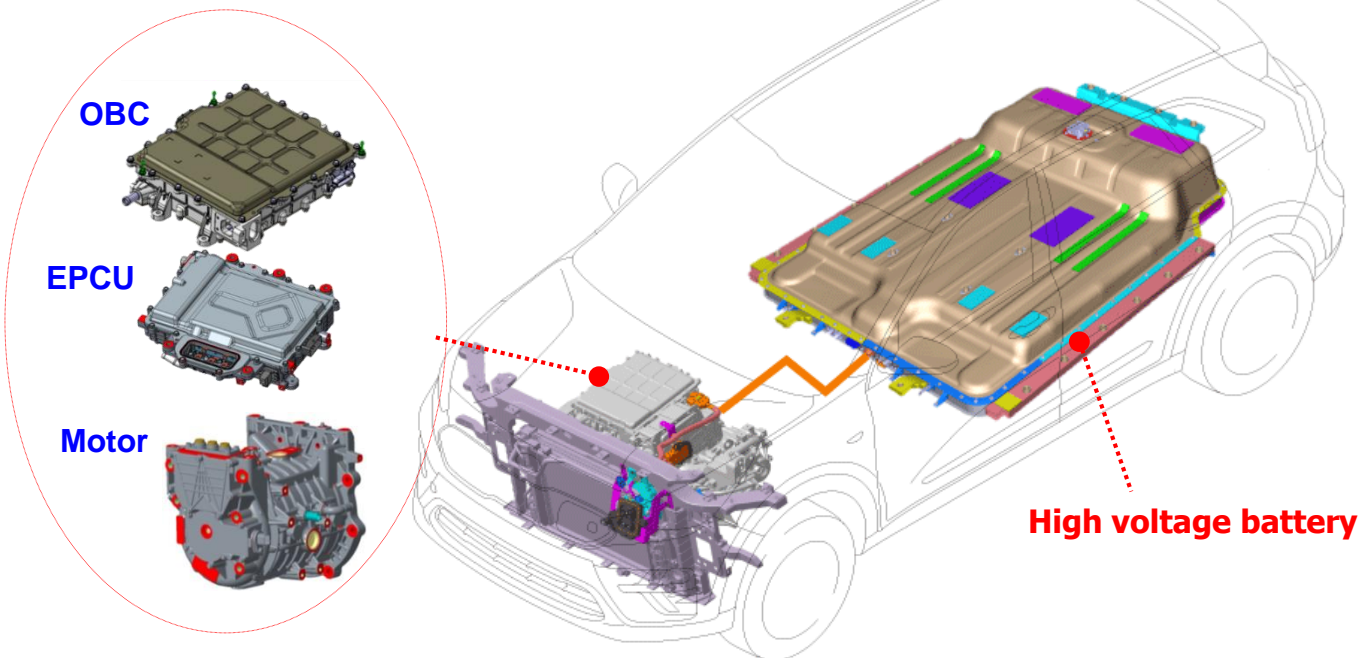

EPCU

The EPCU is the main HV control unit & includes an Inverter and LDC (Low Power DC-DC Converter) in one housing. The inverter converts DC to AC to supply electricity to the motor. It also converts AC to DC to charge the high voltage battery. The LDC converts high voltage electricity to 12 voltage to charge the 12V auxiliary battery.

⚠ WARNING Capacitor in EPCU

- *There is the capacitor inside the EPCU. Wait 5+ minutes for the capacitor to discharge after removing the service plug.*

On-Board Charger (OBC)

The OBC is the HV battery charging equipment that converts external AC to DC or direct DC to DC, to charge the high voltage battery.

Motor

The electric motor of the EV converts electrical energy into motive force with a Max. power of 201Hp (150kW) and Max. torque of 291lb-ft (395Nm).

5. Stored Energy / Liquid / Gases / Solids

5.1 High Voltage System

High Voltage Battery

The HV lithium-ion polymer battery supplies and stores electric energy from the traction motor, and is located under the Niro EV chassis.

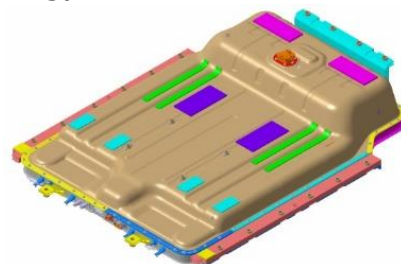

12V Auxiliary Battery

The 12V auxiliary battery is located in the left side of the electric motor room, and powers all of the vehicle's standard electronics like radio, lights, door locks, power windows, etc. Also, it powers the EPCU (Electric Power Control Unit) which controls the high voltage current to main electronic systems like the motor and high voltage junction box.

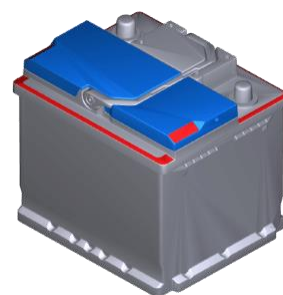

※ Specification

Motor		Type	Permanent magnet synchronous motor
		Max. Output (kW)	Long-range : 150 Economy : 100
		Max Torque (Nm)	395
EPCU	Inverter	Input Voltage(V)	245 ~ 421
	LDC	Max. Output (kW)	1.8
High Voltage Battery		Type	Lithium-ion polymer
		Rated Voltage (V)	Long-range : 352.8 (240~412) Economy : 324 (225~387)
		Energy (kWh)	Long-range : 64 Economy : 39.2
		Quantity for Pack (Cell / Module)	Long-range : 98 cells / 5 modules Economy : 90 cells / 3 modules

5. Stored Energy / Liquid / Gases / Solids

5.2 High Voltage Orange Cabling

The high voltage cabling is orange, per Society of Automotive Engineers (SAE) standards. Cables run under the floor of the vehicle and connect the high voltage battery to the EPCU, Motor, LDC, Inverter, OBC, A/C compressor and other high voltage components located towards the front of the vehicle.

The presence of orange cables under the hood, in the under-floor battery compartment, or HV cables under the car, identifies the vehicle as an electric vehicle.

WARNING High Voltage Cables

- *Never cut or disconnect the high voltage orange cabling and connectors without first disabling the HV system by removing the safety plug (refer to page 10).*
- *Exposed cables or wires may be visible inside or outside the vehicle. Never touch the metal chassis wires, cables, connectors, or any electric components before disabling the system.*

Failure to follow these instructions will lead to serious bodily injury or death by electrical shock.

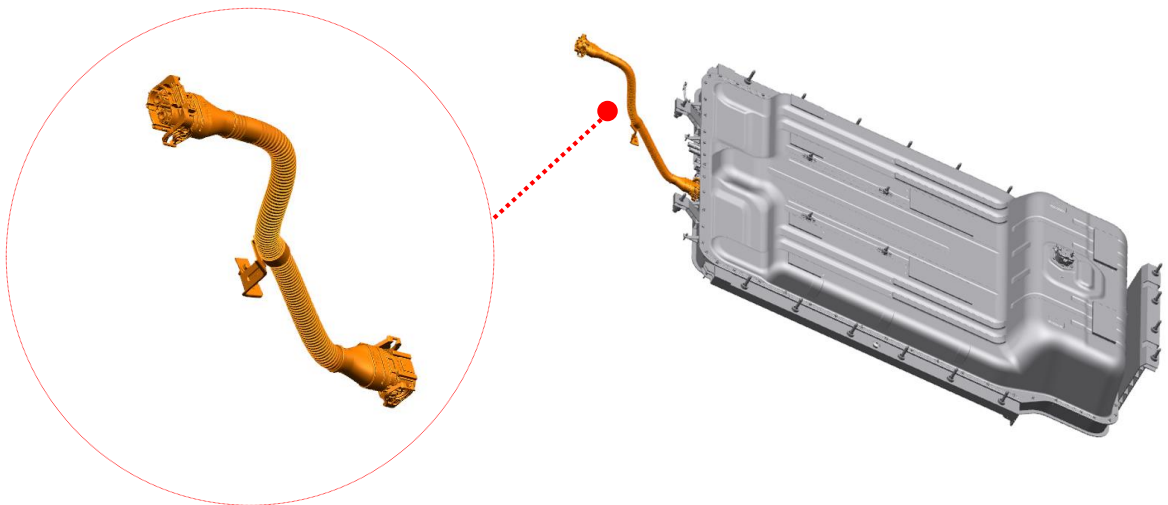

6. In Case of Fire

6.1 Firefighting Operations

Strict precautions must be taken while conducting firefighting operations due to following reasons:

- Lithium-ion Polymer batteries contain gel electrolyte that can vent, ignite, and produce sparks when subjected to temperatures above 300°F.
- Vehicle may burn rapidly with a flare-burning effect.
- Even after the high-voltage battery fire appears to have been extinguished, renewed or delayed fire can occur.
- Use a thermal imaging camera to ensure the high voltage battery is completely cooled before leaving the incident.
- Always advise second responders that there is a risk of the battery re-igniting.
- In a fire, submersion or a collision that has compromised the high voltage battery, always store it in an open area with no exposures within 50 feet.
- A burning battery could release hydrogen fluoride, carbon monoxide, and carbon dioxide gasses. Use NIOSH/MSHA approved full-face self-contained breathing apparatus (SCBA) with full protective gear. Even if the high voltage battery pack is not directly involved in a vehicle fire, approach the vehicle very carefully.

6.2 Extinguishers

- Small fires that do not involve the high voltage battery should be extinguished using an ABC fire extinguisher. (ex. Fire caused by wiring harnesses, electrical components, etc.)
- Do not attempt to extinguish fires that involve the high voltage battery with small amounts of water as this can result in electrocution. Fires that involve the high voltage battery should be extinguished using large amounts of water(Max 10,000 liter) to cool the high voltage battery. Fire fighters should not hesitate to pour larger amounts of water on the vehicle in such scenarios. Make sure the battery is fully cooled to avoid fire re-ignition.

6. In Case of Fire

6.3 How to Deal with the Situation

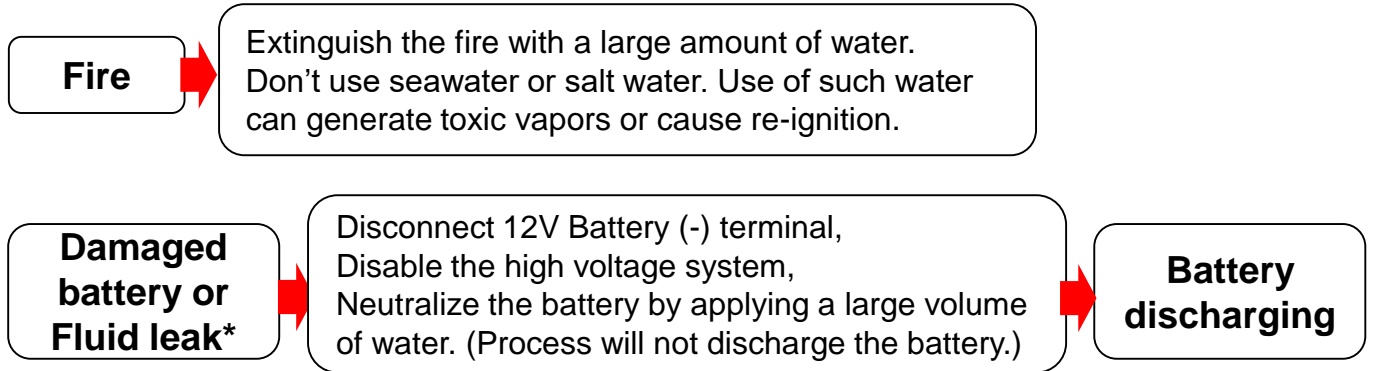

*To be used if electrolyte solution leakage or damage to the high voltage battery casing is observed.

6.3.1 Vehicle Fire

- Use a large volume of water (max. 100,000 liter). Water must cool down the battery.
- If water is applied directly onto the high voltage battery module inside the casing, it will better cool the battery. (But, never attempt to penetrate the HV battery or its casing to apply water.)



- Putting water into the high voltage battery can be difficult due to the battery case.
- Put water through the hole that might be made due to the accident or fire.

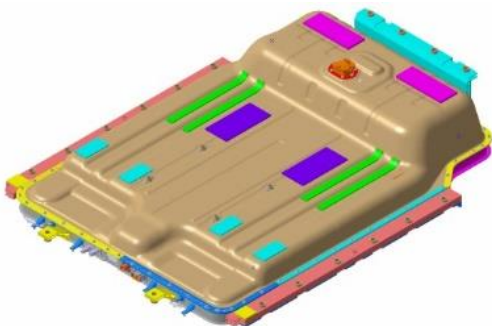

6. In Case of Fire

6.3.2 High Voltage Battery Damage and Fluid Leaks

If electrolyte solution leakage or any damage to the Lithium ion battery casing is observed, the first responders should attempt to neutralize the battery by applying a large volume of water to the battery pack while wearing appropriate Personal Protective Equipment (PPE). The neutralization process helps stabilize the thermal condition of the battery pack but does not discharge the battery.

- Do not put any smoke, spark, flame around the vehicle.
- Do not touch or step on the spilled electrolyte.
- If electrolyte leak occurs, wear appropriate solvent resistant PPE and use soil, sand, or a dry cloth to clean up the spilled electrolyte. Be sure to adequately ventilate the area.

WARNING Electrolyte Irritation

The high voltage battery contains electrolyte solution. To avoid exposure to electrolyte solution and serious personal injury, always wear appropriate solvent resistant PPE (Personal Protective Equipment) and SCBA (Self-Contained Breathing Apparatus).

- *Electrolyte solution is an eye irritant. In the event of contact with eyes, rinse with plenty of water for 15 minutes.*
- *Electrolyte solution is a skin irritant. Therefore, in the event of contact with skin, wash off with soap.*
- *Electrolyte liquid or fumes coming into contact with water will create vapors in the air from oxidization. These vapors may irritate skin and eyes. In the event of contact with vapors, rinse with plenty of water and consult a doctor immediately.*
- *Electrolyte fumes (when inhaled) can cause respiratory irritation and acute intoxication. Inhale fresh air and wash mouth with water. Consult a doctor immediately.*

6. In Case of Fire

6.4 High Voltage Battery Re-ignition by Stranded Energy

Damaged cells in the high voltage battery can experience thermal runaway* and re-ignition. To prevent re-ignition, the first responder and second responder need to be aware of the risk of stranded energy* which remains in the damaged cells and can lead to re-ignition.

*Thermal runaway : The originating cause of thermal runaway is generally short-circuiting inside a battery cell and a resulting increase in the cell's internal temperature. Battery produces heat with thermal runaway and it can spread from one battery cell to many cells, in a domino effect.

*Stranded energy : Energy remains inside any undamaged battery cells after the accident. Stranded energy can cause a high voltage battery to reignite multiple times after a fire has been extinguished.

How to Prevent Re-ignition (Mitigating Stranded Energy Risk)

1. 12V battery (-) terminal disconnection (To depower battery management system)
2. High voltage shut off
*refer to page 8-12
3. Discharging the high voltage battery
*refer to page 25-26

7. In Case of Submersion.

7.1 Submerged or Partially Submerged Vehicles

Some emergency responses can involve a submerged vehicle. The Niro EV does not have high voltage components on the vehicle's body or framework. It is safe to touch the vehicle's body or framework if there is no severe damage to the vehicle, whether it is in water or on land.

In the event that the vehicle is submerged or partially submerged, remove the vehicle from the water before attempting to disable the vehicle. Drain the water from the vehicle. Use one of the methods described in page 8-12 to disable the vehicle.

Then, discharge the battery by referring to page 25-26.

WARNING

- *If severe damage causes high voltage components to become exposed, responders should take appropriate precautions and wear appropriate insulated personal protective equipment.*
- *Do not attempt to remove a safety plug while the vehicle is in water.*

Failure to follow these instructions can lead to death or serious injury by electrocution.

8. Towing / Transportation / Storage

8.1 Towing and Transportation

In the event of an accident, the high voltage system must be disabled. The safety plug must be removed from the high voltage battery according to one of the methods described in page 8-12 to disable the vehicle.

Towing the Niro EV Vehicle is not different from towing a conventional FWD vehicle.

If emergency towing is necessary, we recommend having it done by an authorized Kia dealer or a commercial tow-truck service. Proper lifting and towing procedures are necessary to prevent damage to the vehicle.

The use of wheel dollies or flatbed is recommended.

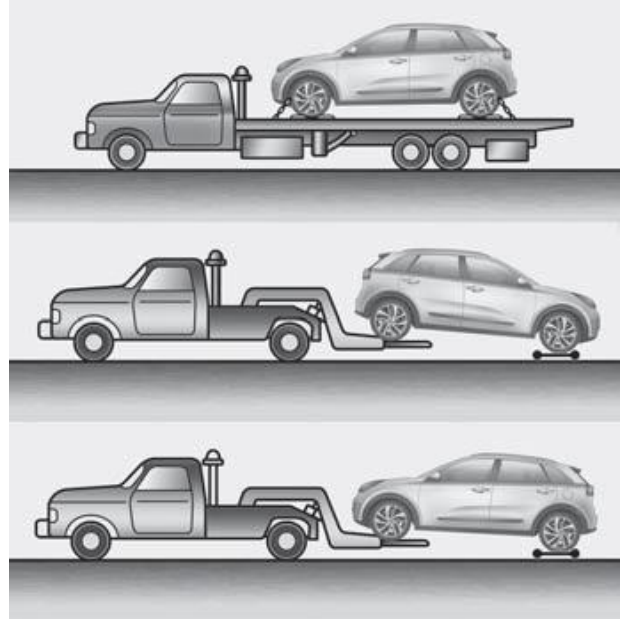

WARNING

- *Never tow the vehicle with the front wheels on the ground (forward or backward), as this may cause fire or damage to the motor.*
- *When towing the Niro EV in an emergency without wheel dollies :*
 1. *Set the ignition switch in the ACC position.*
 2. *Place the transmission shift lever in N*
 3. *Release the parking brake.*



8. Towing / Transportation / Storage

8.2 Storage of Damaged Vehicle with the Damaged Battery (Discharge)

- Drain fluids and water, then disconnect the negative (-) terminal of the 12 V battery.
- In addition, remove the water used for the extinguisher inside the battery or vehicle, then remove the service plug from the high voltage battery before storing a damaged vehicle.
- Place the vehicle in an open space away from any structure, vehicle, or building.
- Then, keep on eye on the vehicle until the discharging procedures are completed.
- **If the battery can be removed from the vehicle by moving the vehicle on the lift, remove and discharge the battery. (refer to the next page)**
- **If the battery can't be removed, set the water pool and pouring water until the entire battery is submerged.**

Water pool condition : tap water or pond water that does not contain salt

- Maintain this water level for at least 90 hours.
- Then, put salt into the water pool to make 3.5 % salt water.
- Wait for additional 48 hours in salt water.
- Drain the water by removing the BMU service cover.

WARNING Battery Discharging

- *DO NOT USE SALT WATER for the first step.*
- *A large volume of flammable hydrogen gas can be generated in salt water due to electrolysis.*
- *After submerging the vehicle in pure water for at least 90 hours, put salt in the water pool.*

BMU (Battery Management Unit) service cover

Battery discharging

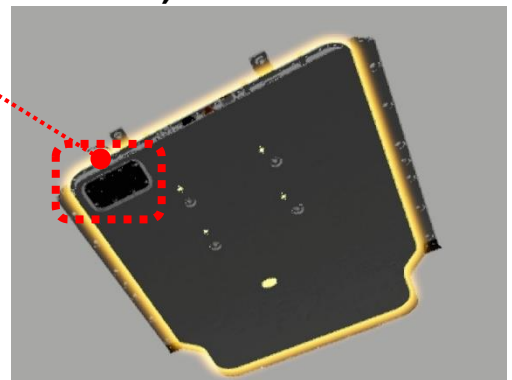

8. Towing / Transportation / Storage

8.3 Damaged Battery Storage

- To store the damaged battery safely, the battery must be discharged.
- If the battery can be removed from the vehicle, discharge the battery to prevent re-ignition.

⚠ WARNING

- *Extinguish all smoke, spark, flame around the vehicle.*
- *Electrolyte solution is a skin irritant.*
- *Do not touch or step on the spilled electrolyte.*
- *If electrolyte leak occurs, wear appropriate solvent resistant PPE and use soil, sand, or a dry cloth to clean up the spilled electrolyte. Be sure to adequately ventilate the area.*

- Prepare water that does not contain salt such as tap water or pond water.
- Leave the battery in water for at least 90 hours.
- Then, put salt in water to make 3.5% salt water.
- Wait for additional 48 hours in salt water.
- Take out the battery from the container and dry it.

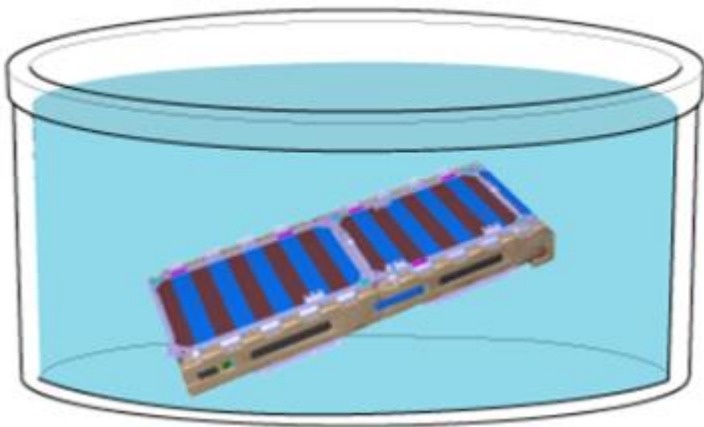

9. Important Additional Information

9.1 Emergency Starting

Jump Starting

Do not attempt to jump start the high voltage battery, as it cannot be jump started. In case of full discharge of the high voltage battery, the vehicle must be towed as mentioned on the previous page.

In case the 12V auxiliary battery is discharged, connect a starting device to the jump terminal in the motor room as you would any 12V battery (see image). Refer to the “Emergency Starting” section of the Owner’s Manual for additional information. Connect jumper cables in the order shown in the image and disconnect in reverse order.

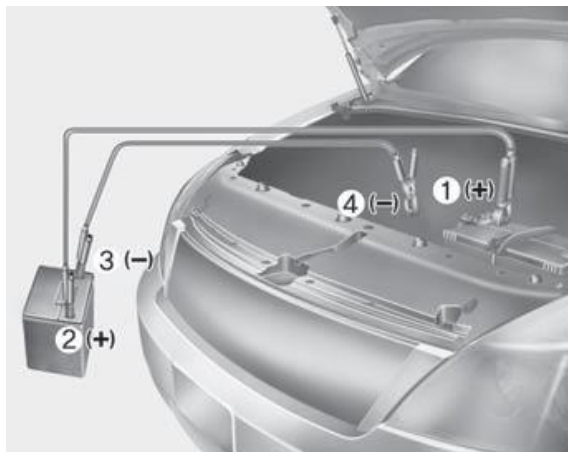

WARNING

Do not attempt to jump start the Niro EV high voltage battery.

Failure to follow these instructions will lead to serious bodily injury or death by electrical shock.

Jump Starting Procedure

1. Make sure the booster battery is 12-Volt and that its negative terminal is grounded.
2. If the booster battery is in another vehicle, do not allow the vehicles to come in contact.
3. Turn off all unnecessary electrical loads.
4. Connect the jumper cables in the exact sequence shown in the illustration.

First connect one end of a jumper cable to the positive terminal of the discharged battery (1), then connect the other end to the positive terminal on the booster battery (2).

Proceed to connect one end of the other jumper cable to the negative terminal of the booster battery (3), then the other end to a solid, stationary, metallic point away from the fuse box (4).

9. Important Additional Information

9.2 Airbag system (SRS : Supplemental Restraint System)

Airbag

Six (7) airbags are installed in the Niro EV, located in the areas shown in the image below. Before performing any emergency procedure, make sure the vehicle ignition switch is turned off and disconnect the negative connector from the 12V auxiliary battery (located in the left side motor compartment) to prevent accidental deployment of undeployed airbags.

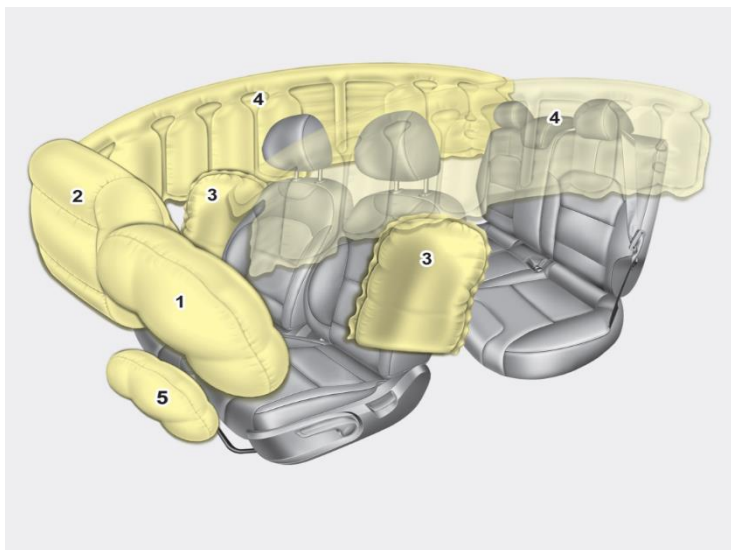

- (1) Driver front airbag
- (2) Passenger front airbag
- (3) Side airbag (x2)
- (4) Curtain airbag (x2)
- (5) Driver's knee air bag

* The actual air bags and seats in the vehicle may differ from the illustration.

Seat Belt Pretensioner

In the Niro EV, the driver's and front passenger's seat belts are equipped with pretensioners. When the seat belt pretensioners are activated in a collision, a loud noise may be heard and fine dust, which may appear to be smoke, may be visible in the passenger compartment. These are normal operating conditions and are not hazardous. The seat belt pretensioner assembly mechanisms may become hot during activation, and may need several minutes to cool down after they have been activated.

9. Important Additional Information

Airbag System Components

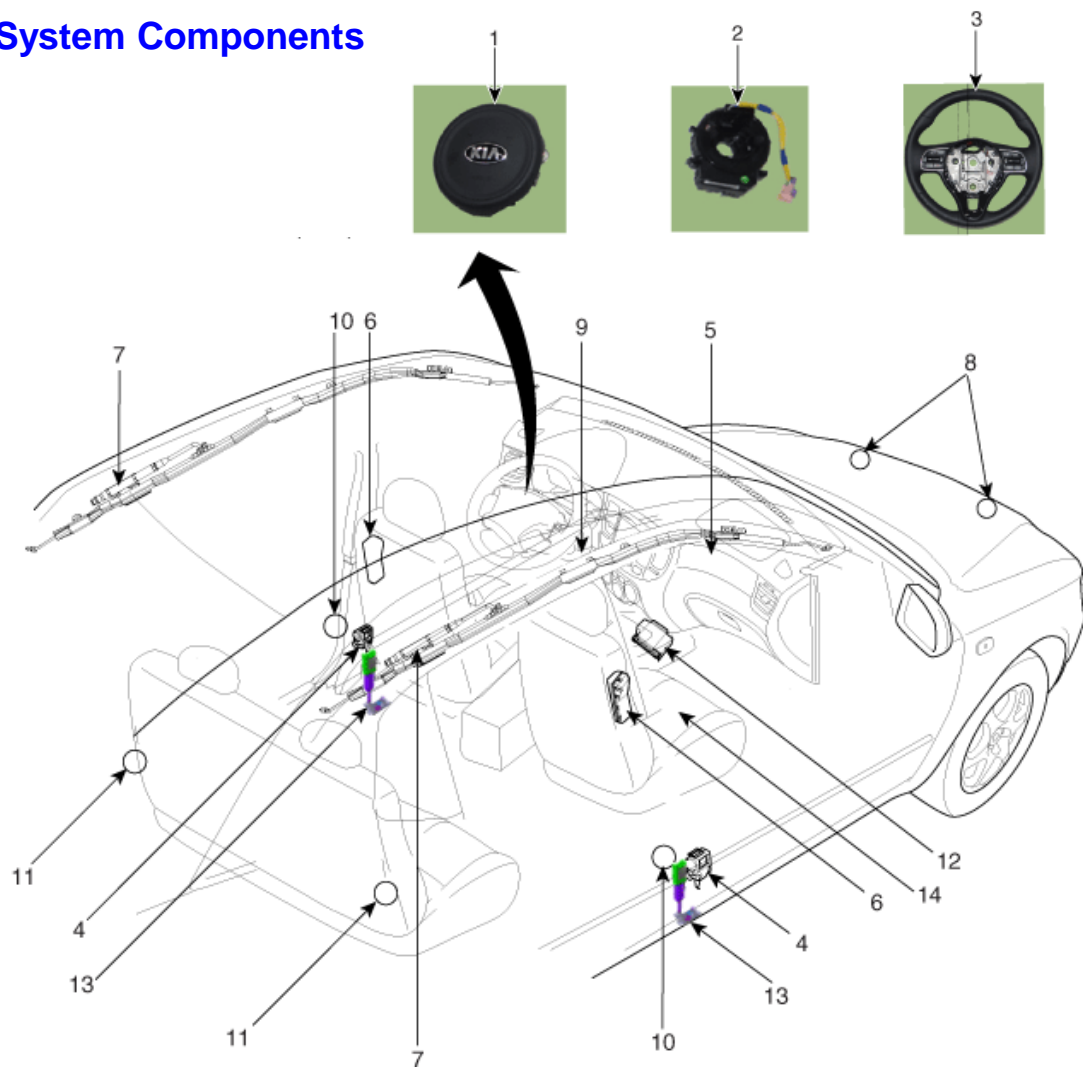

- | | |
|---------------------------------|--|
| 1. Driver Airbag (DAB) | 8. Front Impact Sensor (FIS) |
| 2. Clock Spring | 9. Knee Airbag (KAB) |
| 3. Steering Wheel | 10. Pressure Side Impact Sensor (PSIS) |
| 4. Seat Belt Pretensioner (BPT) | 11. Rear Side Impact Sensor (RSIS) |
| 5. Passenger Airbag (PAB) | 12. Supplemental Restraint System Control Module |
| 6. Side Airbag (SAB) | 13. Emergency Fastening Device (EFD) |
| 7. Curtain Airbag (CAB) | 14. Occupant Classification System (OCS) |

9. Important Additional Information

Seat Belt System



⚠ WARNING Undeployed Airbags

To avoid injuries caused by accidental deployment of undeployed airbags

- *Do not cut the red colored part shown in the image above.*
- *Make sure the vehicle ignition switch is turned off, disconnect the negative cable from the 12V auxiliary battery (located in the left side of motor room) and wait 3 minutes or longer to allow the system to deactivate.*

Failure to follow any of these instructions may result in serious injury or death from accidental deployment of the airbag system.