

2017 Acura NSX

Towing Requirements



Flat bed equipment is the only way you can safely transport your vehicle.

Any other towing method will damage the vehicle's drive system.

Loading cargo bed length: 5710mm

Loading cargo bed width: 2060mm

Cargo bed plate angle: 1.4 to 2.5deg

Boarding approach plate length: 1300mm

Boarding approach angle: 4.9deg

Tow hook location

The vehicle's tow eyelet can be found in the trunk area. Release the two tie down straps, and you'll see the eyelet inserted into foam as shown below.

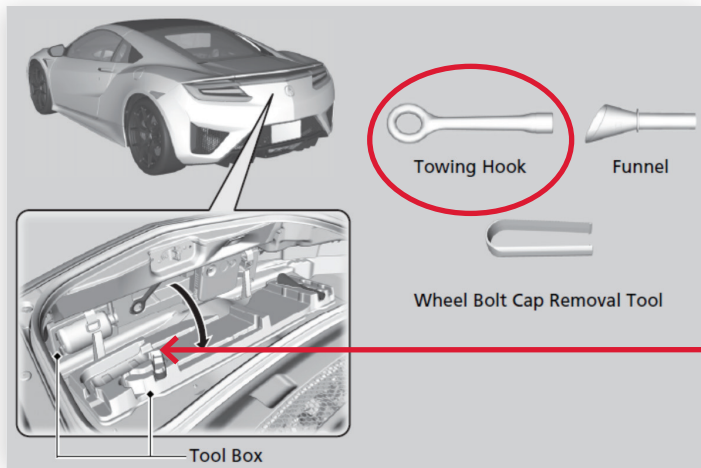

Eyelet location



Remove cover from front bumper with plastic trim device



Tow eyelet inserted into front bumper location

Towing onto flat bed using floor ramps

Set up vehicle for loading with eyelet and ramps to provide sufficient clearance without damage to the diffuser. Tow specialist needs to continually monitor front and rear clearance during winching.



Caution while loading onto flat bed



The vehicle will need to be winched to the flat bed deck using ramps to eliminate potential damage to the diffuser.



Tie Down

Vehicles are only to be retained with Nylon 8 Point Carrier Tie Down Kits.



Release line tension on winch to “unload” tow. Remove eyelet. Place back into trunk location and transport to dealership.